



FRANKLIN

DURASEAL™

**High Integrity, Double Block
and Bleed Plug Valve**

An improved valve with a proven history

We took an alternative path. Unlike many valve manufacturers who often strip valves in their quest to reduce manufacturing costs, we have taken a proven double block and bleed plug valve and improved its design.

With the new DuraSeal™, you get the proven advantages of a valve that has been considered the standard of quality since 1951. To improve the valve's integrity, we have incorporated a superior slip design and more durable body. To improve performance and longevity, we have incorporated a more reliable stem seal design.

In short, the new Franklin DuraSeal™ is made to last - not to make a quick sale.

Reliable double protection mechanical seal

The Franklin DuraSeal™ plug valve seals mechanically. During rotation of the plug there is no abrasion or wear between the sealing surfaces. When the slips reach the closed position they expand firmly into the valve body creating a primary elastomeric and secondary metal-to-metal backup seal. The DuraSeal™ does not require sealant under any circumstance to seal.

Fast Low Torque Operation

The DuraSeal™ can be easily automated using hydraulic or pneumatic or electric actuators. Torque requirements are low. In smaller sizes only two and one quarter turns can fully open or close the valve.

Field Repairable/Interchangeable Parts

DuraSeal™ parts are completely interchangeable with the original 800 Series General Valve Twin Seal™ double block and bleed plug valve. DuraSeal™ components manufactured from superior materials can upgrade existing TwinSeals™ in the field. The DuraSeal™ can be repaired inline after depressurizing and draining the valve without special tools. Simply remove the valve's lower plate or bonnet and replace the slip/seal assemblies from top or bottom of the valve.

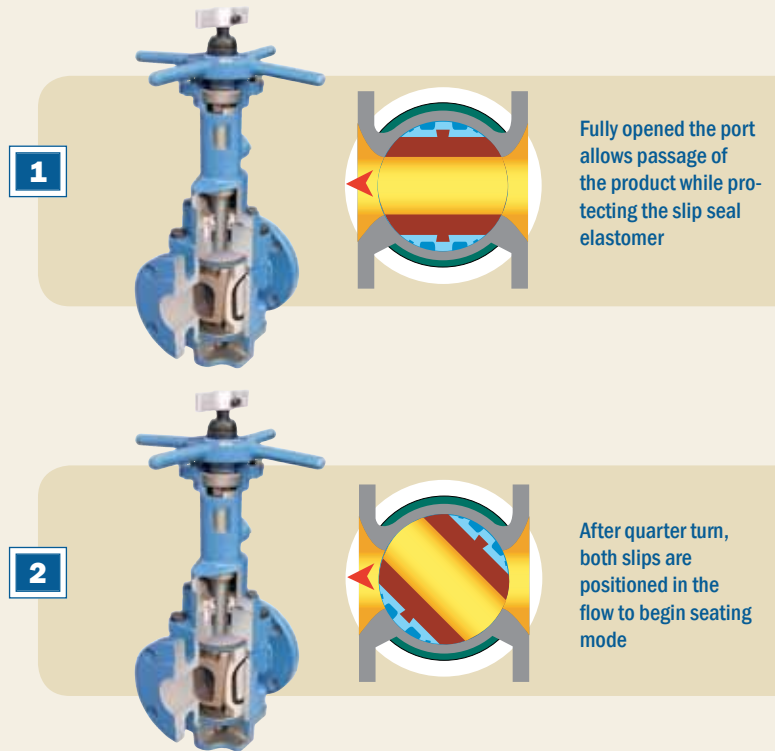

Applications

With bubble-tight fire-safe sealing integrity and the ability to double block and bleed from a single valve, the DuraSeal is an excellent choice for applications that require frequent isolation and testing of gas or liquids.

- **Product manifolds • Measurement units**
- **Isolation of processing equipment**
- **Loading Racks and Tank Isolation**

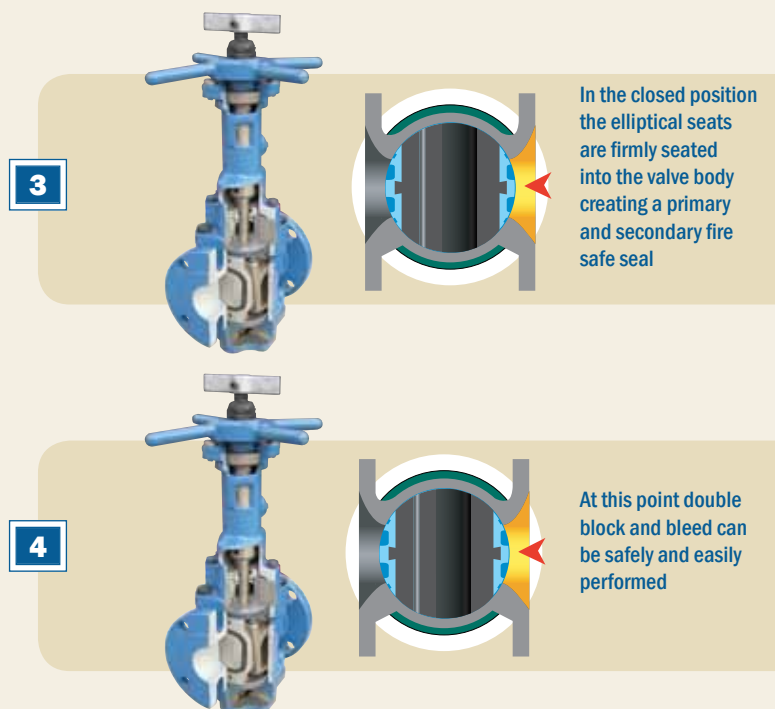

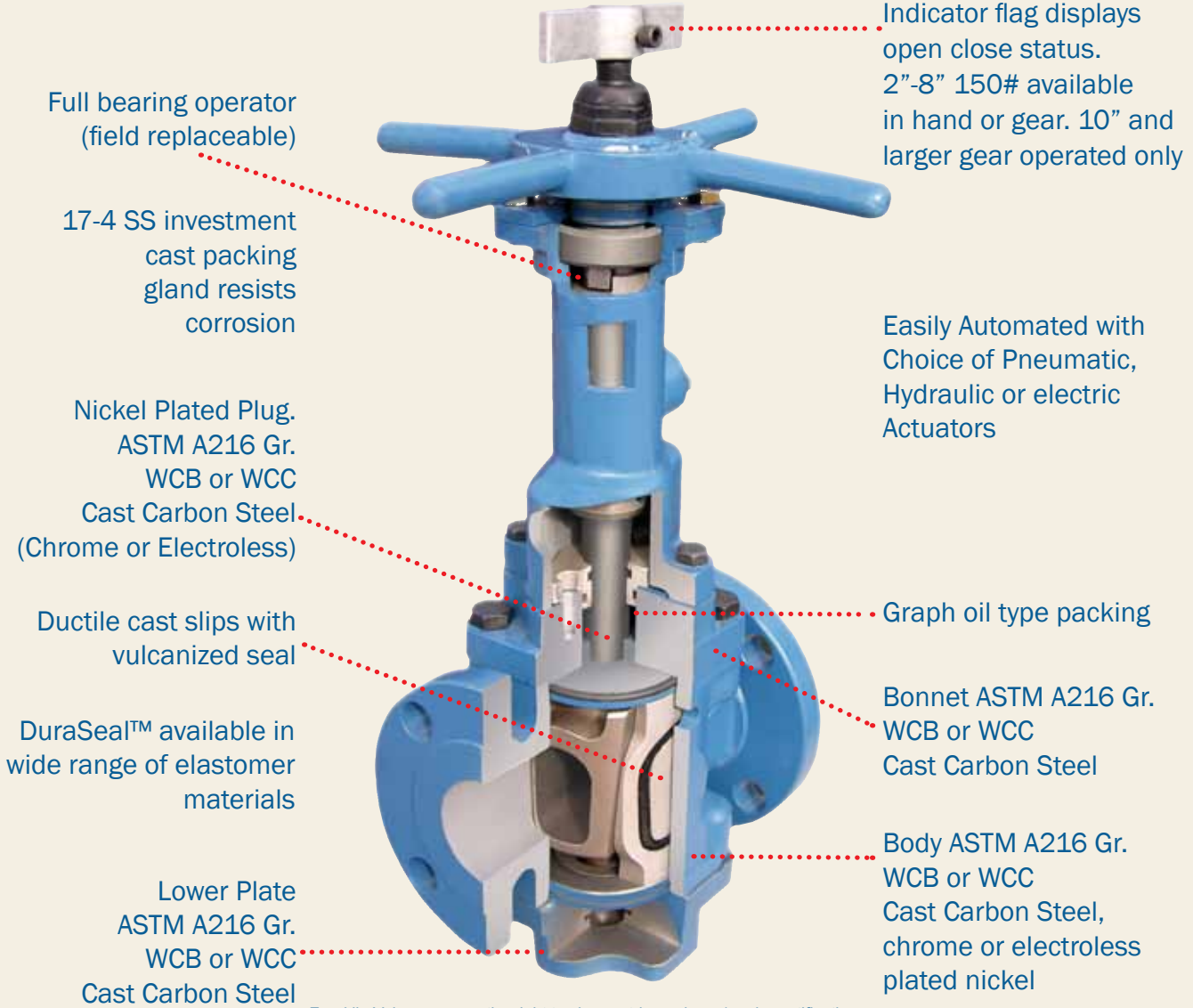

MANUAL BLEED

DTR

CUSTOM CONFIGURATIONS

BLEED CONFIGURATIONS



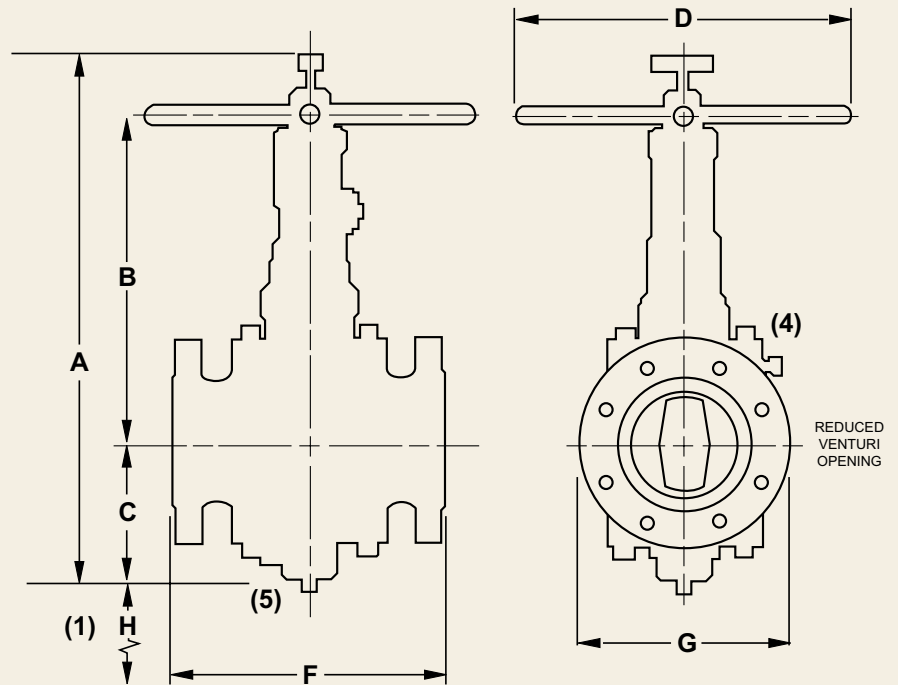

TYPICAL HAND OPERATED VALVE

CLASS	SIZE	MODEL	OPER.	A	B	C	D	F	G	H	WEIGHT(lbs)	(3)	(4)	(5)
ANSI 150	2	D711	100	17	11	4 ½	10	7	6	3	48	NONE	3/8 NPT	1/4 NPT
	3	D711	100	17	11	4 ½	10	8	7 ½	3	62	NONE	3/8 NPT	1/4 NPT
	4	D711	200	27	16	7	20	9	9	4 ½	132	NONE	1/2 NPT	1/4 NPT
	6	D711	200	32 ½	20 ½	9	20	10 ½	11	8	214	(4) ¾" 10 UNC	1/2 NPT	1/4 NPT
	8	D711	300	36	22	10 ½	20	11 ½	13 ½	11	388	(4) ¾" 10 UNC	1/2 NPT	1/4 NPT
ANSI 300	2	D721	100	17	11	4 ½	10	8 ½	6 ½	3	54	NONE	3/8 NPT	1/4 NPT
	3	D721	100	17	11	4 ½	10	11 ⅛	8 ¼	3	76	NONE	3/8 NPT	1/4 NPT
	4	D721	200	27	16	7	20	12	10	5	158	NONE	1/2 NPT	1/4 NPT
	6	D721	300	32 ½	20 ½	9	20	15 ⅞	12 ½	8	318	NONE	1/2 NPT	1/4 NPT
ANSI 600	2	D741	200	24 ½	15 ½	15 ½	20	11 ½	6 ½	2 ½	100	NONE	1/2 NPT	1/4 NPT
	3	D741	200	26	16	16	20	14	8 ¼	3 ½	142	NONE	1/2 NPT	1/4 NPT
	4	D741	300	29 ½	19	19	20	17	10 ¾	4	230	NONE	1/2 NPT	1/4 NPT

(1) H-Minimum clearance required to replace slips.
 (3) Number and size tapped holes. Each flange.

(4) Tapped bleeder hole.
 (5) Bottom plate drain hole.

Dimensions "F" & "G" are nominal.
 All others are rounded off to the nearest half-inch.

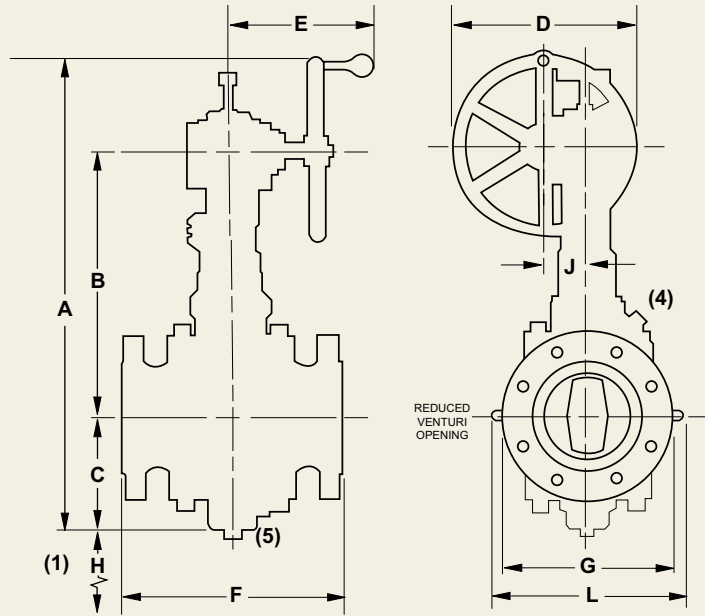

TYPICAL GEAR OPERATED VALVE

	SIZE	MODEL	OPER.	A	B	C	D	E	F	G	H	J	WEIGHT(lbs)	(3)	(4)	(5)
ANSI 150	2	D711	101	21	12	4 ½	8	10 ½	7	6	3	1 ½	64	NONE	3/8 NPT	1/4 NPT
	3	D711	101	21	12	4 ½	8	10 ½	8	7 ½	3	1 ½	76	NONE	3/8 NPT	1/4 NPT
	4	D711	201	27	15 ½	7	10	11	9	9	4 ½	1 ¾	140	NONE	1/2 NPT	1/4 NPT
	6	DA711	301	36	20 ½	8 ½	14	12 ½	10 ½	11	8	3	264	(4) ¾" 10 UNC	1/2 NPT	1/4 NPT
	8	D711	301	39 ½	22	10 ½	14	12 ½	11 ½	13 ½	11	3	436	(4) ¾" 10 UNC	1/2 NPT	1/4 NPT
	10	D711	301	42	23	12	14	12 ½	13	16	14	3	532	(4) 7/8" 9 UNC	1/2 NPT	1/4 NPT
	12	D711	401	55 ½	31	14 ½	20	12 ½	14	19	16	3 ½	844	(4) 7/8" 9 UNC	1/2 NPT	1/4 NPT
	14	D711	401G	57	32 ½	16	20	12 ½	15	21	19	3 ½	1074	(4) 1"- 8 UNC	1/2 NPT	1/2 NPT
	16	D711	501	67	39	18	20	14 ½	16	23 ½	21	5	1488	(8) 1" 8 UNC	1/2 NPT	1/2 NPT
	20*	D711	501	64	37	17	20	14 ½	40	27 ½	17	5	3326	NONE	1 NPT	1/4 NPT
24*	D711	501	78 ½	44	24 ½	20	14 ½	48	32	20	5	6264	NONE	1 NPT	1 NPT	
ANSI 300	2	D721	101	21	12	4 ½	8	10 ½	8 ½	6 ½	3	1 ½	78	NONE	3/8 NPT	1/4 NPT
	3	D721	101	21	12	4 ½	8	10 ½	11 1/8	8 1/4	3	1 ½	102	NONE	3/8 NPT	1/4 NPT
	4	D721	201	27	15 ½	7	10	11	12	10	4 ½	1 ¾	162	NONE	1/2 NPT	1/4 NPT
	6	D721	301	36	20 ½	8 ½	14	12 ½	15 7/8	12 ½	8	3	348	NONE	1/2 NPT	1/4 NPT
	8	D721	401	49 ½	28	11	20	12 ½	16 ½	15	11	3 ½	666	(4) 7/8"- 9 UNC	1/2 NPT	1/4 NPT
	10	D721	401	52	29	12 ½	20	12 ½	18	17 ½	13	3 ½	888	(4) 1"- 8 UNC	1/2 NPT	1/4 NPT
	12	D721	501	63 ½	36 ½	16 ½	20	14 ½	19 ¾	20 ½	16	5	1414	(8) 1 1/8" 8 UNC	1/2 NPT	1/4 NPT
	14	D721	401	58 ½	34 ½	14 ½	20	14 ½	30	23	15	5	1990	NONE	1/2 NPT	1/2 NPT
ANSI 600	2	D741	201	24 1/2	15 1/2	15 1/2	20	10 1/2	11 1/2	6 1/2	2 1/2	1 1/2	100	NONE	1/2 NPT	1/4 NPT
	3	D741	201	26	16	16	20	10 1/2	14	8 1/4	3 1/2	1 1/2	142	NONE	1/2 NPT	1/4 NPT
	4	D741	301	29 1/2	19	19	20	11	17	10 3/4	4	1 3/4	230	NONE	1/2 NPT	1/4 NPT
	6	D741	401	45	26	9	20	12 1/2	22	14	10	3 1/2	696	NONE	1/2 NPT	1/4 NPT
	8	D741	401	48	27	11	20	13 1/2	26	16 1/2	12	5	1102	NONE	1/2 NPT	1/4 NPT
	10	D741	501	62 1/2	36 1/2	16	20	14 1/2	31	20	8	5	1974	NONE	1/2 NPT	1/2 NPT
	12	D741	501	62 1/2	38	17	20	14 1/2	33	22	10	5	2532	NONE	1/2 NPT	1/2 NPT

(1) H-Minimum clearance required to replace slips.
 (2) Approximate Weights (Lbs.)
 (3) Number and size tapped holes.

(4) Tapped bleeder hole.
 (5) Bottom plate drain hole.
 Dimensions "F", "G" & "J" are exact. All others are rounded off to the nearest half-inch.

(6) Dimensions are not certified.
 Contact the factory for certified drawings.
 * Reduced Round Opening

Flow Coefficients (CV)

VALVE	CV
2" 150# D711	195
2" 300# D721	205
2" 600# D741	290
3" 150# D711	200
3" 300# D721	210
3" 600# D741	300
4" 150# D711	530
4" 300# D721	570
4" 600# D741	850
6" 150# D711	1415
6" 300# D721	1770
6" 600# D741	2265
8" 150# D711	2400
8" 300# D721	3000
8" 600# D741	3600
10" 150# D711	3500
10" 300# D721	3540
10" 600# D741	5100
12" 150# D711	4000
12" 300# D721	4700
12" 600# D741	9200
14" 150# D711	5500
14" 300# D721	6000
16" 150# D711	6600
16" 300# D721	9400
20" 150# D711	15700
24" 150# D711	24000

The Cv listing above is in gallons per minute of flow of water at 60 degrees F w/ (1) PSI pressure drop across the valve

Franklin Valve DuraSeal Torque & Turns

VALVE	OPERATOR	TORQUE	TURNS	SEATING THRUST	M/KG
2" 150# D711	100 HWO	46	1.8	1,000	6.4
2" 150# D711	101 Gear	2.4	17	1,000	0.33
2" 300# D721	100 HWO	30	1.8	2,618	4.14
2" 300# D721	101 Gear	6	17	2,618	0.83
2" 600# D741	201 Gear	19	13	2,618	2.6
3" 150# D711	100 HWO	15	2	1,605	2.1
3" 150# D711	101 Gear	6	16	1,605	0.83
3" 150# D711	101 Gear	3	17	1,605	0.83
3" 300# D721	101 Gear	6	16	4,202	1.9
3" 300# D721	100 HWO	30	1.8	4,202	4.1
3" 600# D741	201 Gear	28	16	8,407	3.9
4" 150# D711	200 HWO	25	2.7	2,566	12.4
4" 150# D711	201 Gear	7	20	2,566	3.2
4" 300# D721	200 HWO	25	2.7	6,713	3.5
4" 300# D721	201 Gear	45	10	6,713	6.2
4" 600# D741	301 Gear	38	18	13,437	5.3
6" 150# D711	301 Gear	19	18.5	5,218	2.6
6" 150# D711	200 HWO	30	2.7	5,218	4.1
6" 300# D721	301 Gear	60	18.5	13,666	8.3
6" 600# D741	401 Gear	117	29	33,412	16
8" 150# D711	301 Gear	41	18.5	8,893	12
8" 300# D721	401 Gear	105	21	22,500	14.5
8" 600# D741	401 Gear	125	21	31,070	17.3
10" 150# D711	301 Gear	66	20	12,987	9.1
10" 300# D721	401 Gear	138	25	34,000	19
10" 600# D741	501 Gear	185	46	85,500	25.5
12" 150# D711	401 Gear	90	23	18,638	13.1
12" 300# D721	501 Gear	184	41	49,498	13.1
12" 600# D741	501 Gear	219	46	120,948	30.3
14" 150# D711	401 Gear	92	28	22,282	12.7
14" 300# D721	501 Gear	209	43	57,680	28.9
16" 150# D711	501 Gear	104	45	25,004	14.4
20" 150# D711	501 Gear	158	45.5	48,922	21.9
24" 150# D711	501 Gear	167	53	77,140	23



Franklin Valve Extension Kit

Franklin makes available both vertical and lateral extensions. In ordering, always specify dimensions B or E. Type A extension is suitable for underground burial. Type C extension should be supported if dimension E is over 36".

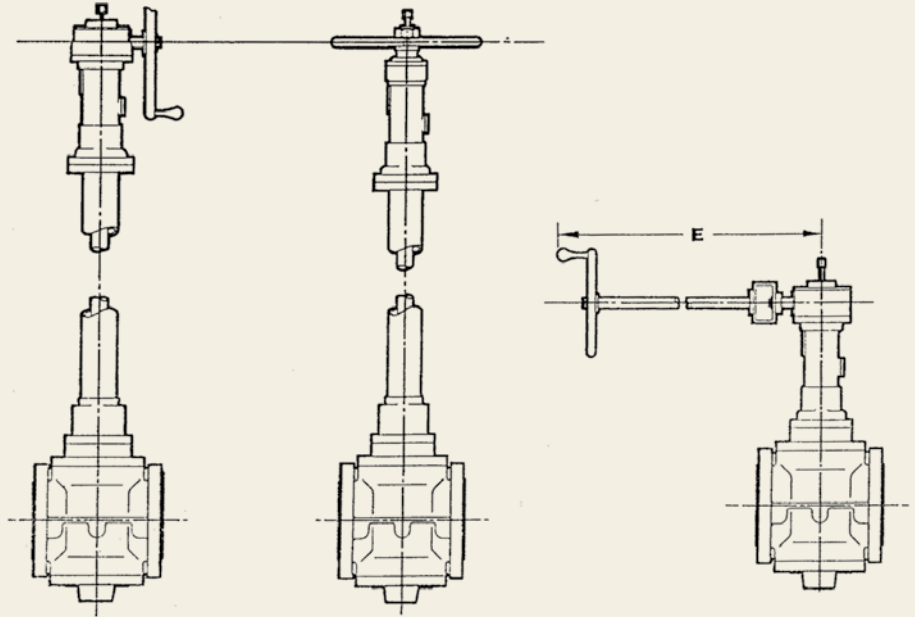

**GEAR OPERATOR
EXTENSION-CLOSED
TYPE "A"**

**HAND OPERATOR
EXTENSION-CLOSED
TYPE "A"**

**GEAR OPERATOR
EXTENSION-LATERAL
TYPE "C"**

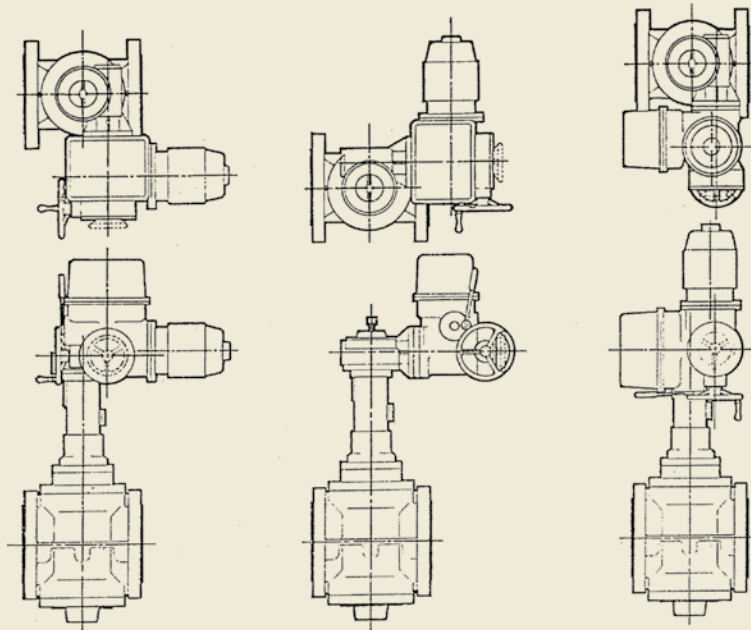
Franklin Electric Motor Actuation

STYLE "A" -
(Standard mounting)
MOTOR OPERATOR
MOUNTED PARALLEL
TO PIPE LINE

STYLE "B" -
MOTOR
OPERATOR
MOUNTED AT
RIGHT ANGLE
TO PIPE LINE

STYLE "C" -
MOTOR
OPERATOR
MOUNTED
VERTICAL
TO PIPE LINE

WHEN ORDERING ELECTRIC MOTOR OPERATORS, SPECIFY THE FOLLOWING DATA:
INSTALLATION

1. Mounting style
2. Valve installation attitude
(for proper location of breathers and drains)

TYPE OF VALVE

3. Valve figure number
4. Size
5. ANSI rating

OPERATING CONDITIONS

6. Differential pressure in psi
7. Operating time in seconds

ELECTRICAL DATA

8. Explosion proof NEMA VII or weatherproof NEMA IV
9. Phase, Cycle, Volts - controls and motors

SPECIAL FEATURES

10. Gear limit switch (2 or 4 train)
11. Reversing controller (if separate, it is to be explosion proof NEMA VII, or weatherproof)
12. Breather or drains, if desired
13. Space heater, if desired
14. Control transformer, if desired (specify voltage)
15. Other special requirements

FACILITY

Located in Houston, TX Franklin Valve was established in 2005. What started out as a valve repair shop, now features an impressive 25,000 square foot state of the art valve manufacturing facility.

The facility is separated into 3 areas: new manufacturing, fabrication, and quality control.



7720 Bluff Point Drive
Houston, Texas 77086
Phone: 713-812-7100
Fax: 713-686-5158
www.franklinvalve.com

QUALITY

The Management Team at Franklin Valve is committed to the continued enhancement of product excellence, reliability and service through the dynamics of its Quality Assurance System. The responsibility of this system and its people is to maintain effective controls for monitoring both quality and manufacturing processes and equipment; to provide live feedback concerning the current state; to initiate statistical metrics that validate that state, its reliability levels and the basis for improving our future state. Those statistical metrics are Safety, Quality, Delivery & Cost.

THIS CONCEPT IS USED BUT NOT LIMITED TO THESE FUNCTIONS:

- I. INBOUND RAW MATERIAL INSPECTION**
- II. PROCESS / PRODUCT QUALIFICATION**
- III. OUTSOURCED PROCESSES**
- IV. IN PROCESS ASSEMBLY AND FINAL TESTING**

Franklin's systemic approach is the foundation which allows us to confidently maintain the ultimate quality of our finished products to our customers.



Petroleum Measurement Equipment Company, Inc.

Authorized Franklin Valve Distributor

15794 Capitol Hill Montgomery, TX 77316

Sales and Support: (770) 886-0889 (office) (770) 331-2667 (cell)
curtisbunting@petroleummeasurement.us